



Operation Manual

Air Saver Unit

ASV200 Series

Thank you for your choice of Kuroda Pneumatics LTDs' product on this time. Please read this operation manual carefully and use the product correctly. Keep this operation manual in case that questions arise about this product in the future. If this operation manual becomes unreadable or parts of the unit are missing, consult our distributors or Kuroda Pneumatics Ltd. sales offices.

Kuroda Pneumatics LTD.
(Parker Hannifin Automation Division Japan)
Distributed by: Hose & Fittings, Etc.
916.372.3888
www.hoseandfittingsetc.com

Contents

For safety use P2

Warning P2

1. ASV200 Series general information P3

2. Ordering Instructions P3

3. Specifications P3

4. Dimensions & Installation P4

5. Notes for usage P5



6. Failure and trouble shooting P6

7. Maintenance and disassembly P6

For Safety Use

Be sure to read the following instructions before use.

The following safety precautions are provided to prevent damage and injury to personnel and to provide instructions on the correct usage of this product. These precautions are classified into 3 categories: "CAUTION", "WARNING" and "DANGER" according to the degree of possible injury or damage and the degree of impendence of such injury or damage. Be sure to comply with all precautions along with JIS B 8370(*1) and ISO 4414(*2), as they include important content regarding safety.

 Danger :	Indicates an impending hazardous situation which may arise due to improper handling or operation and could result in serious personal injury or death.
 Warning :	Indicates a potentially hazardous situation which may arise due to improper handling or operation and could result in serious personal injury or death.
 Caution :	Indicates a potentially hazardous situation which may arise due to improper handling or operation and could result in personal injury or property-damage-only accidents.

*1 JIS B8370 : General Rules for Pneumatic Systems

*2 ISO 4414 : Pneumatic fluid power-General rules relating to systems.



Warning

- **The applicability of pneumatic equipment to the intended system should be judged by the pneumatic system designer or the personnel who determined specifications for such system.**

As operating conditions for products contained in this instruction are diversified, the applicability of pneumatic equipment to the intended system should be determined by the pneumatic system designer or the personnel who determined specifications for such system after conducting an analysis or testing as necessary. Before making a system, the system designer should thoroughly examine all specifications for such a system and also take into consideration the possibility of any trouble with the equipment.

- **The pneumatic equipment should be handled by persons who have sufficient knowledge and rich experience.**

Improper handling of compressed air will result in danger. Assembling, operation and maintenance of machinery using pneumatic equipment should be performed by persons who have sufficient knowledge and rich experience.

- **Never operate machinery nor remove the equipment until safety is assured.**

Before checking or servicing machinery and equipment, be sure to check that steps for prevention of dropping or runaway of the driven component have been completely taken.

When removing the equipment, make sure that the above-mentioned safety measures have been done beforehand. Then turn off air supply and power to the system and purge compressed air in the system.

When restarting machinery and equipment, check that proper prevention of malfunction has been provided for and then restart carefully.

- **When using the pneumatic equipment in the following conditions or environments, take the proper safety measures and consult Kuroda Pneumatics LTD beforehand.**

- Conditions and environments other than specified and outdoor use.
- Applications to nuclear power equipment, railroads, aircraft, vehicles, medical equipment, equipment connected with food and drink, amusement facilities and safety devices such as emergency interruption devices, clutch/brake circuits for a press and the likes.
- Applications which require extreme safety and will also greatly affect human and property.

1. General Information

This product is a pulse air generation unit with built-in soft seal pneumatic valve. This product is mainly for reducing air consumption in air blowing applications.

2. Ordering Instructions

ASV200 - AA - M5
 ① ② ③

- ① Model No. ASV200 (Air Saver Unit pneumatic operate, internal pilot type)
- ② Voltage/Wiring AA : All air (No electrical wiring)
- ③ Port size M5

3. Specifications

Model No.	Unit	ASV200
Way to operate		Pneumatic, Internal pilot type
Fluid	-	Non-lubricated/lubricated air
Port size	-	M5
Sonic speed conductance	dm ³ /(s·bar)	0.36
Critical pressure ratio	-	0.25
Effective area (reference)	mm ²	1.8
Ambient temperature	°C	-5~50 ^{Note 1)}
Operating pressure range	MPa	0.3~0.7 ^{Note 2)}
Max. frequency	Hz	5
Weight	g	210

Note 1) When ambient temperature of the unit goes below 5°C, complete dry air shall be supplied to prevent freezing.

Note 2) ASV200 is internal pilot operated valve. If the supply pressure come to be lower than 0.3 MPa, ASV200 might not be switched properly. Please make sure to supply specified operating pressure.

4. Dimensions & Installation

ASV200-AA-M5

Unit (mm)

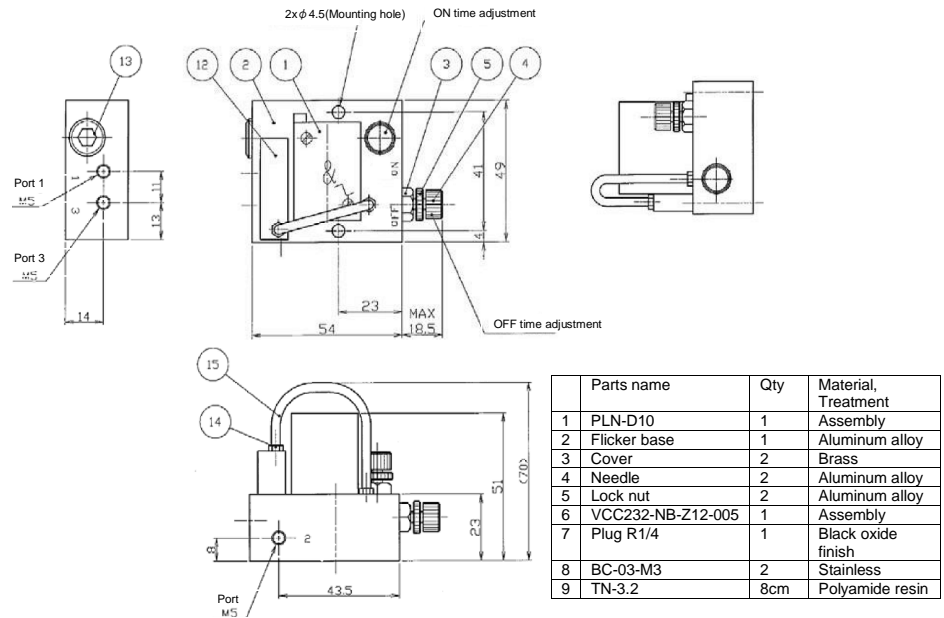

(Piping)

Port 1 : Supply port (Compressor side)

Port 2 : Outlet port (Blow nozzle side)

Port 3 : Exhaust port * In order to avoid dust, air muffler (model No.SL-M5) is recommended to attach.

Preparation for air supply and adjustment of pulse time

- 1) After piping to Air Saver Unit and while the supply air is shut off, fully close the ON time adjustment needle (clockwise rotation) and fully loosen the OFF time adjustment needle (counter clockwise rotation). It is suggested to mark these needle positions, it may be convenient to use those marks later as an indication of needle rotation.
- 2) Turn on air to the supply port, air should pass to the output port continuously.
- 3) Slowly loosen the ON time adjustment needle in CCW direction. A pulsed air blow with short OFF time will start. It is suggested to stop rotating the ON time adjustment needle at around 1 turn.
- 4) Next, adjust the OFF time by slowly tightening the OFF time adjustment needle in CW direction. The OFF time of the pulsed air blow will get longer. Stop rotating the OFF time adjustment needle at around 8 turns. 4Hz (ON/OFF about 50%) air blow should be achieved.
- 5) Use the procedure of 4) as a starting point and make the frequency and duty adjustments required in your application by using the ON time and OFF time adjustment needles.
- 6) Fix the adjustment position by tightening lock nuts on adjustment screws.

Adjustment of pulse air ON/OFF time

	Tighten (Clockwise)	Loosen (Counter clockwise)
Pulsed air cycle	Slow	Fast
ON time adjustment needle	Longer ON time	Shorter ON time
OFF time adjustment needle	Longer OFF time	Shorter OFF time

***Adjust frequency of pulsed air to less than 5 Hz. If frequency of pulsed air is higher than 5 Hz, operation of the pneumatic circuit (logistic element) may become unstable.**

How to stop the operation of Air Saver Unit

- 1) Fully tighten ON time adjustment needle.
- 2) Fully tighten OFF time adjustment needle. In case that needles are fully tightened and output air blow is continued, push the manual button of logical element temporarily.
- 3) Cut the supply air to the Air Saver Unit.

Caution

When air blow is not desired, be sure to cut air supply to the Air Saver Unit. Air blow may come out even the ON/OFF time adjustment needles are fully tightened. This unit is not designed to be an "OFF" valve.

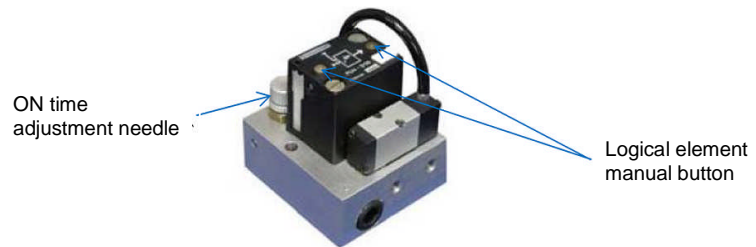
**5. Notes for usage**

A) Before piping

Thoroughly flush the inside of any pipes to remove chips, coolant, dust and etc.

B) Air quality

- 1) Air Saver requires an air filter with filtration of 5 μ m or finer.
- 2) If it is difficult to make filter drain management periodically, Kuroda Pneumatics LTD recommends setting up an air filter with automatic drain mechanism.
- 3) Be sure to take proper maintenance for a compressor. If sludge produced in compressor oil enters pneumatic equipment, it will cause operation failure of pneumatic equipment. Kuroda Pneumatics LTD recommends setting up a coalescing filter after a filter.

C) Pneumatic circuit

This unit is internal pilot operated valve. To avoid malfunctions due to pressure drops, the air supply pressure must be more than 0.3MPa at all times. To avoid pressure drops during air blowing process, set up relatively higher supply pressure and use tubes with proper diameter.

D) Stopping the air blow

Be sure to cut air supply to Air Saver Unit when air blow is not used. Blown air may come out even if the ON/OFF time adjustment needles are fully tightened.

6. Failure and trouble shooting

a) Failure and countermeasure

Failure condition		Cause	Countermeasure
The unit cannot be operated.		Supply air might be less than 0.3MPa during operation.	Adjust supply air pressure properly.
		Valve part is contaminated with dust or sludge.	1) Replace the product. 2) If an air filter is not used, use an air filter. 3) If problem is sludge, use a coalescing filter.
Operating frequency is getting slower.		Dust or high viscosity oil is trapped in the valve and it obstructs the spool.	1) Replace the product. 2) If air filter is not used, use an air filter.
		Contaminant is caught inside of the pneumatic circuit, and it blocks up the flow.	Replace the logic element.
		Contaminant accumulated in the exhaust port, obstructing the air flow.	Clean air mufflers or replace them.
Substantial air leakage is observed.	From main valve part	Spool seal rings are damaged.	Replace the master valve.
	From base gasket	Tightening torque for mounting screws is not enough to mount valve.	Tighten mounting screws to appropriate torque.

7. Maintenance and disassembly

Regarding repair and maintenance, please consult Kuroda Pneumatics LTD.

As a general rule, do not attempt maintenance or disassemble.

If it is absolutely necessary to do maintenance work, keep the following points in mind.

- 1) Make sure that the actuators such as cylinders will not cause damage if they move.
- 2) Cut off electricity.
- 3) Cut off pneumatic pressure and exhaust air in the line.
- 4) Clean up the surroundings of the valve.

Caution

Any attempt to repair and/or disassembling of the product by the user violates the warranty and Kuroda Pneumatics, Ltd. Does not take any responsibility for damage and injury caused by it.